

# Serie Sliding

## SR319SE Nylon Sliding Cable Chain with openable frames

### Inner height (D) 75,5 mm

Strong double share Sideband & Frame construction with large anti-friction triple-pin. The chain incorporates large sliding-skid surfaces to offer durability, even with high speed/loads. Frames openable from outer radius). As standard the chain comes with frames every second link, on request with frames every link. Modular separator systems are available

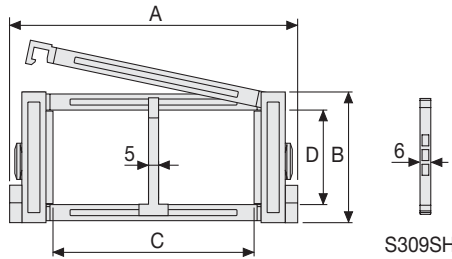

### Separator

- Unassembled Part.no S309S
- Assembled Part.no S309SMC

### Strong-hold separator

for C > 250 mm

- Unassembled Part.no S309SH
- Assembled Part.no S309SHMC

### Pin

Part.no PG319

### Technical characteristics

Speed	4 m/s
Acceleration	13 m/s <sup>2</sup>

For higher requirements please consult our technical dept.

A	B	C	D	R	Weight/m	Chain
mm	mm	mm	mm	mm	kg	Part Number
128	107	64	75,5	200-250-300-350-400-500	4,47	SR319SE064□□□*
148	107	84	75,5	200-250-300-350-400-500	4,53	SR319SE084□□□*
173	107	109	75,5	200-250-300-350-400-500	4,61	SR319SE109□□□*
180	107	116	75,5	200-250-300-350-400-500	4,64	SR319SE116□□□*
203	107	139	75,5	200-250-300-350-400-500	4,71	SR319SE139□□□*
243	107	179	75,5	200-250-300-350-400-500	4,84	SR319SE179□□□*
278	107	214	75,5	200-250-300-350-400-500	4,95	SR319SE214□□□*
304	107	240	75,5	200-250-300-350-400-500	5,04	SR319SE240□□□*
328	107	264	75,5	200-250-300-350-400-500	5,11	SR319SE264□□□*
354	107	290	75,5	200-250-300-350-400-500	5,19	SR319SE290□□□*
378	107	314	75,5	200-250-300-350-400-500	5,27	SR319SE314□□□*
404	107	340	75,5	200-250-300-350-400-500	5,34	SR319SE340□□□*
428	107	364	75,5	200-250-300-350-400-500	5,43	SR319SE364□□□*
552	107	488	75,5	200-250-300-350-400-500	5,85	SR319SE488□□□*

\*Complete the code by inserting the value of the radius (R): Ex. SR319SE116 □□□□  
Chain equipped with nylon frame every pitch: complete the code by inserting the letter D.  
Ex. SR319SE116250 □

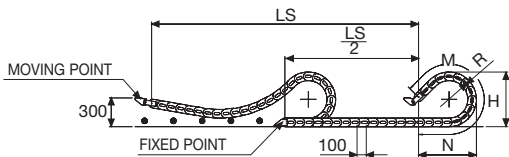

Length of chain (L)

Half travel distance ( $\frac{LS}{2}$ )

plus length of curve (M)

$$L = \frac{LS}{2} + M$$

R	H	N	M
mm	mm	mm	mm
200	507	595	1345
250	607	765	1780
300	707	940	2220
350	807	1110	2655
400	907	1280	3095
500	1107	1625	3970



### End Brackets

The end brackets set allows the two ends of the chain to be attached to the equipment. One set comprises two movable end brackets to install at the moving point and two standard steel end brackets to install at the fixed point.

**Bright Zinc Plated Steel Movable Type\* (moving point)**      **Bright Zinc Plated Steel Type\* (fixed point)**

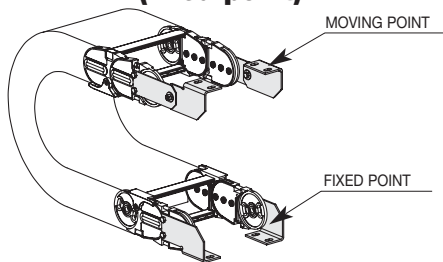
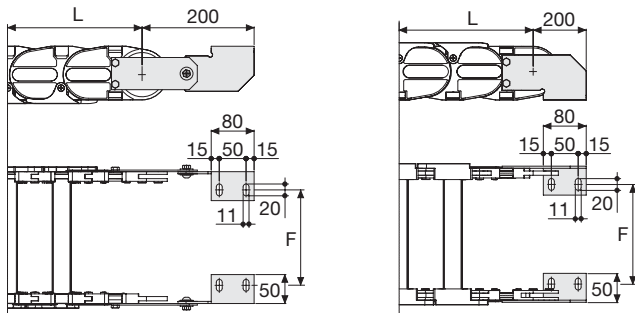

Fig. A  
Chain fixed outside the radius. (Fig A)



Chain Type	F mm
SR319SE064	40
SR319SE084	60
SR319SE109	85
SR319SE116	92
SR319SE139	115
SR319SE179	155
SR319SE214	190
SR319SE240	216
SR319SE264	240
SR319SE290	266
SR319SE314	290
SR319SE340	316
SR319SE364	340
SR319SE488	464

### Bright Zinc Plated Steel Type Part Numbers

Complete Set Assembled	
Chain Type	End Brackets Set
SR319SE...	A319KM

Complete Set Unassembled	
Chain Type	End Brackets Set
SR319SE...	A319K

\*Available on request in stainless steel

### Serie Sliding

## SR319SE

Nylon Sliding Cable Chain with openable frames

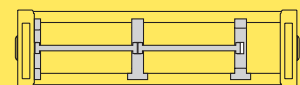

Separation System  
To choose the separators see page. 176

3

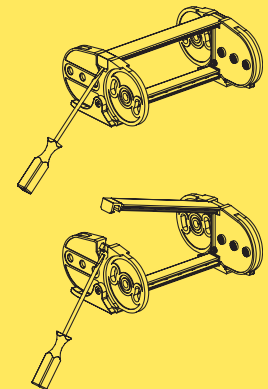

How to open the cover.

For further information please consult Brevetti Stendalto's Technical Office